

APPROVED

REVISIONS				
ZONE	REV.	DESCRIPTION	DATE	APPROVED

**FOR
REFERENCE
ONLY**

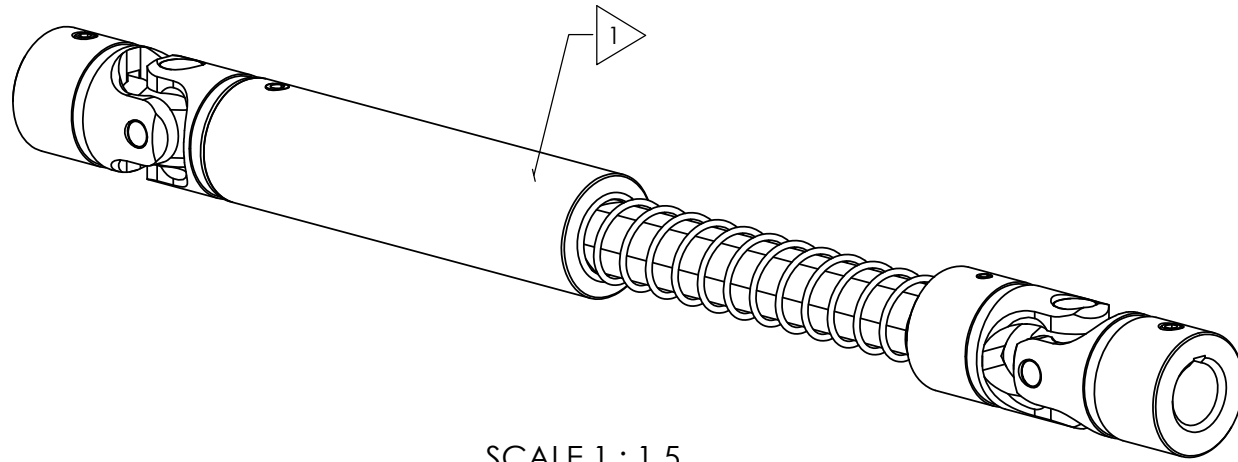

SCALE 1 : 1.5

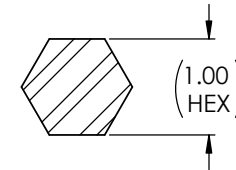

SECTION A-A

SOCKET SET SCREW, 3/8-16 x 3/8", CUP POINT, ALLOY STEEL, 2X

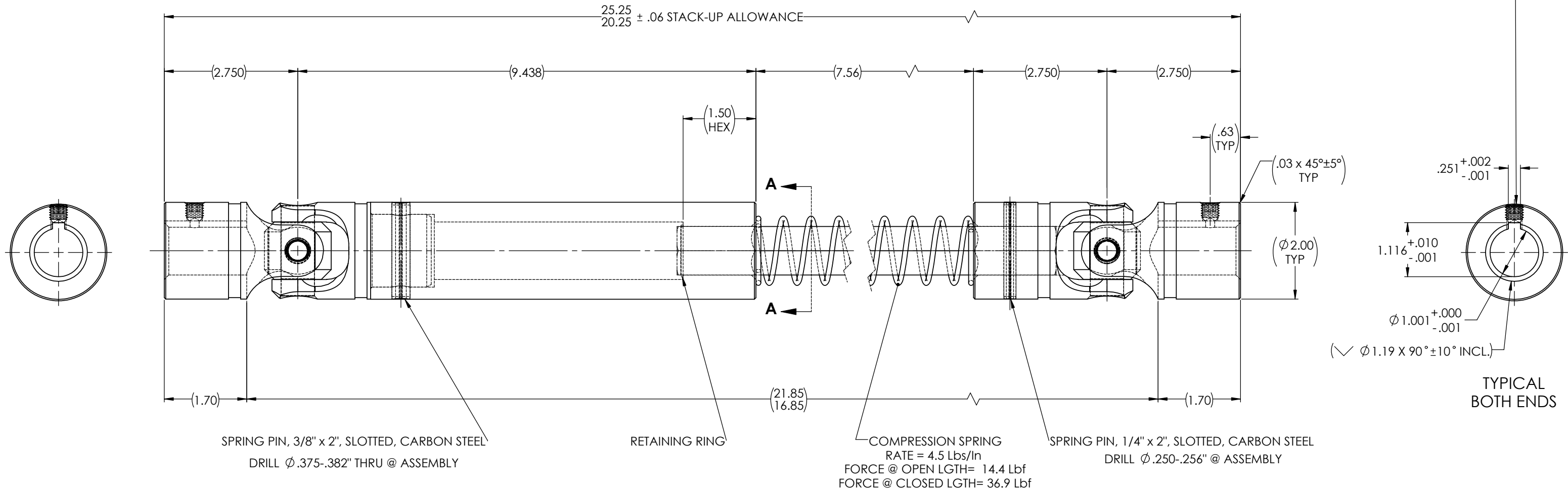

TYPICAL
BOTH ENDS

NOTE(s), UNLESS OTHERWISE SPECIFIED.

1 MARK ASSEMBLY w/"BELDEN" LOGO, PART NUMBER, REVISION LEVEL, DATE OF MANUFACTURE (MO/YR) & BELDEN JOB No.

(2) LUBRICATE UNIVERSAL JOINTS & HEX SHAFT CONNECTION w/ LUBRIPLATE # 1200-2, NLGI GRADE 2, AW/EP, LITHIUM GREASE.

DO NOT SCALE DRAWING

UNLESS OTHERWISE SPECIFIED CHAMFER ALL HOLES BREAK ALL SHARP CORNERS DE-BURR ALL FEATURES	STANDARD TOLERANCES, UNLESS OTHERWISE SPECIFIED DIMENSIONS ARE IN INCHES (mm)	MATERIAL: ALLOY STEEL	INITIALS	DATE	Belden Universal www.beldenuniversal.com
			DRAWN	JP	
TURNED SURFACES: \checkmark ₆₃	ANGULAR MACHINED: ±1.0°	HEAT TREAT: SEE DETAIL DRAWINGS	CHECKED	RNK	02/03/2023
MILLED SURFACES: \checkmark ₁₂₅	FRACTIONAL: ±.015"		ENG APPR.	RNK	09/05/2023
PROPRIETARY AND CONFIDENTIAL THE INFORMATION CONTAINED IN THIS DRAWING IS THE SOLE PROPERTY OF BELDEN UNIVERSAL. ANY REPRODUCTION IN PART OR AS A WHOLE WITHOUT THE WRITTEN PERMISSION OF BELDEN UNIVERSAL IS PROHIBITED.	ALL HOLES TO BE LOCATED ON CENTERLINE (Q) WITHIN .005" T.I.R.	FINISH/COATING: NONE	MFG APPR.	QUALITY	REV
INTERPRET GEOMETRIC TOLERANCES I.A.W. ASME Y14.5			COMMENTS:		SIZE DWG. NO. B TUJ-HD2000x1000K-L
					SCALE: 1:1 WEIGHT (Lbs): 13.481 SHEET 1 OF 2