

APPROVED

| REVISIONS | | | | |
|-----------|------|-------------|------|----------|
| ZONE | REV. | DESCRIPTION | DATE | APPROVED |
| | | | | |

**FOR
REFERENCE
ONLY**

SOC. SET SCREW, 5/16-18 x 1/4, CUP POINT, ALLOY STEEL 2X

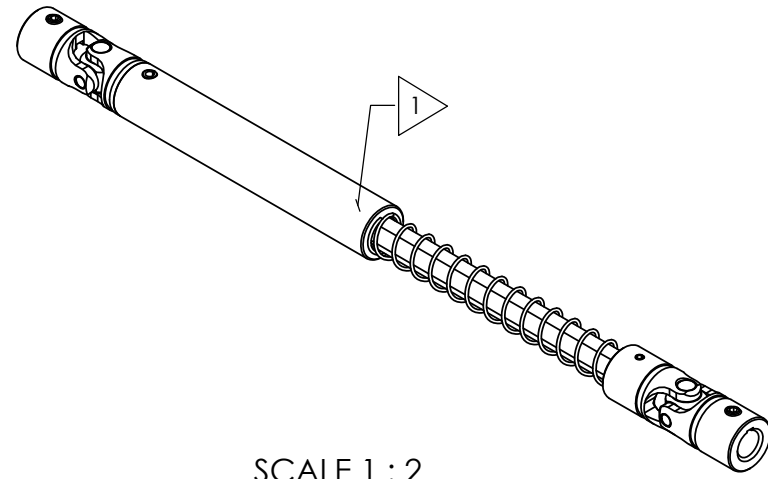

SCALE 1 : 2

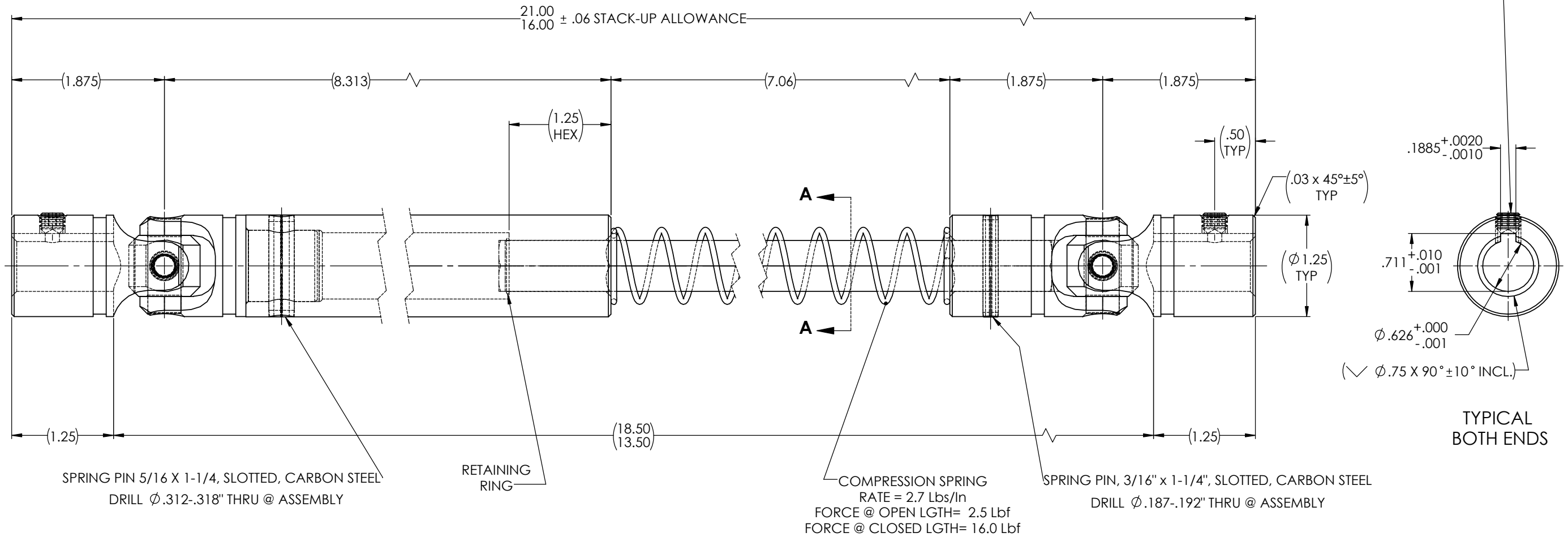
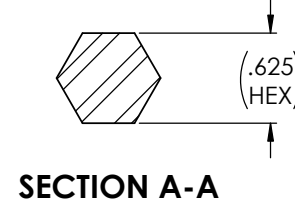

NOTE(s), UNLESS OTHERWISE SPECIFIED.

1 MARK ASSEMBLY w/ "BELDEN" LOGO, PART NUMBER, REVISION LEVEL, DATE OF MANUFACTURE (MO/YR) & BELDEN JOB No.

(2) LUBRICATE UNIVERSAL JOINTS & HEX SHAFT CONNECTION w/ LUBRIPLATE # 1200-2, NLGI GRADE 2, AW/EP, LITHIUM GREASE.

DO NOT SCALE DRAWING

| | | | | | | |
|--|---|---|------------------|--------------------|---|---|
| UNLESS OTHERWISE SPECIFIED CHAMFER ALL HOLES BREAK ALL SHARP CORNERS DE-BURR ALL FEATURES TURNED SURFACES: \checkmark 63 MILLED SURFACES: \checkmark 125 PROPRIETARY AND CONFIDENTIAL THE INFORMATION CONTAINED IN THIS DRAWING IS THE SOLE PROPERTY OF BELDEN UNIVERSAL. ANY REPRODUCTION IN PART OR AS A WHOLE WITHOUT THE WRITTEN PERMISSION OF BELDEN UNIVERSAL IS PROHIBITED. | STANDARD TOLERANCES, UNLESS OTHERWISE SPECIFIED DIMENSIONS ARE IN INCHES (mm) ANGULAR MACHINED: ±1.0° FRACTIONAL: ±.015" TWO PLACE DECIMAL: ±.010" THREE PLACE DECIMAL: ±.005" FOUR PLACE DECIMAL: ±.0005" CONCENTRICITY: .0025" T.I.R. | MATERIAL: ALLOY STEEL HEAT TREAT: N/A FINISH/COATING: NONE | INITIALS JP | DATE 09DEC22 | Belden Universal www.beldenuniversal.com TITLE: ASSEMBLY, DRIVE SHAFT | |
| | | | DRAWN RNK | DATE 02/03/2023 | | SIZE DWG. NO. B TUJ-HD1250x625K-L |
| | | | CHECKED RNK | DATE 09/05/2023 | | REV |
| | | | ENG APPR. RNK | COMMENTS: | | SCALE: 1.5:1 WEIGHT (Lbs): 4.102 SHEET 1 OF 2 |